

# General Specifications

## MODEL UP350 Program Controller



GS 05E01D02-01E

### General

Model UP350 program controller is a precision controller, featuring two program profiles and universal input/output.

For easy operation, it is provided with a large display for process variables, two program operation keys, and a program reset key. For excellent controll, auto-tuning, PID control with the "SUPER" overshoot suppressing function and the "SUPER2" hunting suppressing function are available. It also has a retransmission output and 15V DC loop power supply as standard.

### Main Features

- Extra-large digital display allows the indicated values to be read even from a long distance. LEDs of 20mm height are used for the process variable display.
- It can store two program pattern types. Programmed operation can be started by using the two program operation keys on the front panel and terminated by using the reset key.
- Universal input and output enable users to set or change freely the type of measured inputs (thermocouple, RTD, or DCV), measurement range, type of control output (4 to 20 mA current, voltage pulse, or relay contact, etc. from the front panel.
- Parameters can be easily set using a personal computer. ("Parameter setting tool (model LL100)" sold separately is required.)
- Various communication function are provided. Communication is possible with personal computer, programmable logic controller, and other controllers.

### Function Specifications

#### Program Setting Function

"Program setting" allows the controller's target setpoint to increase or decrease along the program pattern versus time. The instrument, provided with two program patterns, can be operated by using the front panel key or through the external contact. One program pattern consists of 10 broken lines (program segments). If the two program patterns are combined, a program pattern of up to 20 segments can be created. The length of each segment can be specified by the segment time. Users can also configure the number of repeats, event outputs, etc.

- Number of program patterns: 2
- Number of segments/pattern: 10
- Number of program repeat: Unlimited repeats
- Segment time: 0 min. 0 s to 99 min. 59 s, or 0 h 0 min. to 99 h 59 min.

UP350



UP350E

"E" indicates with the model with expanded functions.



Starting/stopping (resetting) a program pattern:

A program pattern can be started or stopped (reset) by key operation.

Temporarily stopping (holding) a program pattern:

A program pattern can be temporarily stopped (hold) by key operation or through the contact input.

Skipping (advancing) the segment of a program:

Available through key operation

Switching between program patterns:

Available through key operation or external contact

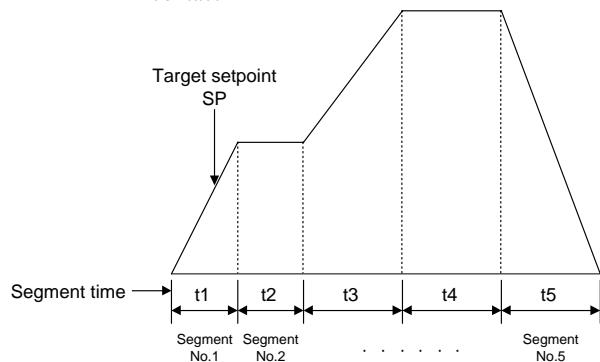

**Wait Function (Guaranteed soak)**

The function to delay the progress of a program pattern if the process variable (PV) has not reached the target setpoint (SP). The wait zone is the deviation band of acceptable PV response is determined, and the wait time is the time to wait for the PV to reach the wait zone. If the PV reaches the wait zone within a certain time (the wait time), then the program will advance to the next segment. If it does not reach the wait zone after the wait time has elapsed, then the program will eventually advance to the next segment.

Wait time: 0 min. 1 s to 99 min. 59 s, or  
0 h 1 min. to 99 h 59 min.

Wait zone: OFF, 0.0 to 10.0 % of measured input range width.

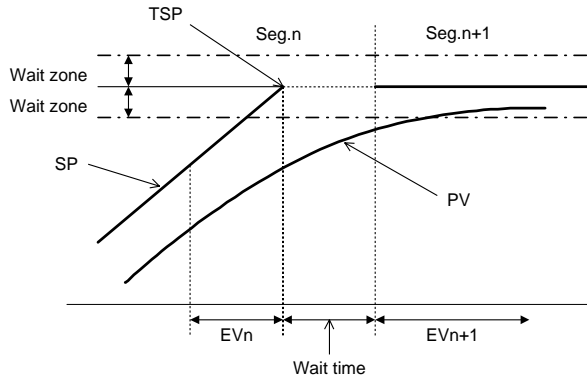

**Program Setting Function and PID Parameter Switching**

PID parameter switching in accordance with the progress of the program pattern is available.

Zone PID: PID parameter selection according to the value of the PV is available. Reference point (setpoint for PID parameter switching) or reference deviation is used for switching.

Reference point method:

Up to two points can be set to divide the PV range up to three zones, and this selects the PID parameter set (PID 1 to 3) according to zone.

Reference point = Measuring input range (0%) ≤ Reference point 1 ≤ Reference point 2 ≤ Measuring input range (100%)

Reference point hysteresis = Fixed to 0.5% of the measured input range width.

Reference deviation method:

Switches the group of PID parameters (PID 4) depending on whether the control deviation is within or over the reference preset amount. This takes priority over the reference point.

Reference deviation = OFF, 0.1 to 100.0% of measured input range width.

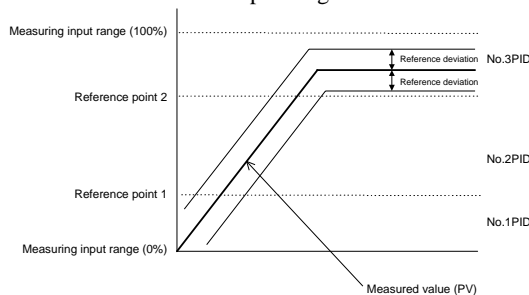

**Time Event: 1 point**

A time event may be set throughout the program pattern progress, by and uses a status lamp or a contact output.

Number of time events: 1 point for each program pattern  
Time event setting points: These output time events according to the elapsed time from the program start.

Time event setting range(ON and OFF): 0 min. 1 s to 99 min. 59 s, or  
0 h 1 min. to 99 h 59 min.

Time event display: 1 point (TIME)

Time event contact output: 1

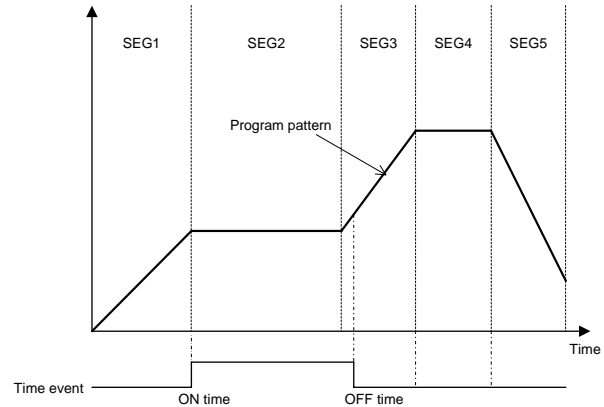

**PV Event: 2 point**

A PV event is a PV/deviation alarm which is configured in accordance with the program pattern. The alarm status is indicated by the event LED on the front of the instrument panel.

Number of PV events:

2 points maximum per program pattern

PV event LEDs:

2 points (PVE1, PVE2)

PV event types:

PV high limit, PV low limit, Deviation high limit, Deviation low limit, Deenergized on deviation high limit, Deenergized on deviation low limit, Deviation high and low limits, High and low limits within deviation, Deenergized on PV high limit, Deenergized on PV low limit

PV event setting ranges:

PV alarm: -100.0 to 100% of measured input range.

Deviation alarm: -100.0 to 100% of measured input range width.

Alarm hysteresis: 0.0 to 100.0% of measured input range width.

**● Control Computation Functions**

Control computation:

Select from the following types of control strategies:

Continuous PID control, time proportional PID control, Relay ON/OFF control

Control cycle time: 250 ms

Number of PID parameter sets: 4

Auto-tuning: Available as standard. If auto-tuning is enabled, the PID constant is set automatically. (Limit cycle method)

“SUPER” function: This suppresses overshooting caused by the sudden change of the target setpoint or disturbance.

“SUPER2” function:

This stabilizes the state of control that is unstable due to hunting, etc. without requiring any change in PID constants, when the load and/or gain varies greatly, or when there is a difference between the characteristics of temperature zones.

### Control Parameters Setting Range

Proportional band: 0.1 to 999.9%

Integral time: 1 to 6,000 s, or OFF (for Manual Reset)

Derivative time: 1 to 6,000 s, or OFF

Manual reset value: -5.0 to 105.0% of output range (functions when integral time is off)

ON/OFF control hysteresis: 0.0 to 100.0% of measured input range width

Direct/Reverse action:

Defining the direction of an increase/decrease in output corresponding to a positive or negative deviation is available.

Anti-reset windup:

When the output of the controller is limited, this stops normal integration to suppress over-integration; instead, it performs anti-reset windup computation.

Control output cycle time: 1 to 1000 s

Preset output value: -5.0 to 105.0% of output range

Output tracking:

Selecting output with bump or without bump is available by changing the PID control mode.

Output limiter:

high limit: Low limit to 105.0% of output range

low limit: -5.0% of output range to high limit

### ● Signal Computation Functions

Measured input configuration:

Bias addition (-100.0 to 100.0% of measured input range width.), first order lag filter (time constant: off, 1 to 120 s)

Contact input function:

Program pattern switching operation, program operation hold mode switching, display key-lock parameter enabled/disabled switching  
For program pattern operation, select from the dual-pattern switching operation and single-pattern operation.

- If the single-pattern operation is selected, program operation hold mode switching can also be used.

- If the dual-pattern switching operation is selected, program operation hold mode switching cannot be used.

If displaying key-lock parameter enabled/disabled switching is used, switching between the single-pattern operation and dual-pattern switching operation is not available.

### ● Display and Operation Function

PV display: 4-digit digital display for engineering data

Setpoint display:

Various types of data, including setpoint (SP), are available selectively on 4-digit digital display.

Status indicating lamps:

2 PV event (alarm) LEDs: PVE1, PVE2

1 time event LED: TME

2 program operation number LEDs: PRG1, PRG2

1 program operation hold LED: HLD (lights up during hold mode)

Operation key:

▲, ▼ key: Increases/decreases the value of setpoint or other parameters which appear on LED display.

SET/ENT key: Sets/changes the setting value, and calls/switches between parameters.

PRG1, PRG2: Program operation control key

RESET: Program operation stop key

SELECT display:

Allows selection and registration of frequently changed parameters from the operation parameters during operation. For example, if the bias parameter is registered in the SELECT display, the setpoint can easily be displayed during operation.

Security function:

An operation inhibiting mode using a password is available.

### ● Communication Functions (optional)

The communication function, provided with the instrument, allows connection to personal computer, programmable logic controller, and other GREEN series controllers.

Communication protocol:

Computer link communication:

Communication protocol with a personal computer

Ladder communication:

Communication protocol with programmable logic controller

MODBUS communication:

Communication protocol with a personal computer or PLC.

Coordinated operation:

Protocol to realize coordinated operation with more than one UT controller in the GREEN series. The UP350 is always configured as a master unit.

Communication interface:

Communication protocol:

Computer link, ladder communication, MODBUS or coordinated operation

Standard: EIA RS485

Maximum number of connectable controllers:

31 Green series controllers

Maximum communication distance: 1,200 m

Communication method:

Two-wire half duplex or four-wire half duplex, start-stop synchronization system, handshaking

Communication rate:

600, 1200, 2400, 4800, 9600 bps

**Status lamps**  
PV event (PVE1, PVE2), time event (TME), operation status of Program pattern 1 or 2 (PRG1, PRG2) hold status (HLD).

**Communication port for light loader**  
Parameters and programs are set via communication from a personal computer.

**Operational keys**  
Increase/Decrease the setting data (▲, ▼)  
Select parameter/Enter the setting data (SET/ENT)  
Start program operation or set a program (PRG1, PRG2)  
Reset to preset output (RESET)

**LED display unit (for PV)**  
Display PV, and error code when error is detected.

**LED display unit (for SP)**  
Display setpoint (SP), setting item/value of parameters.

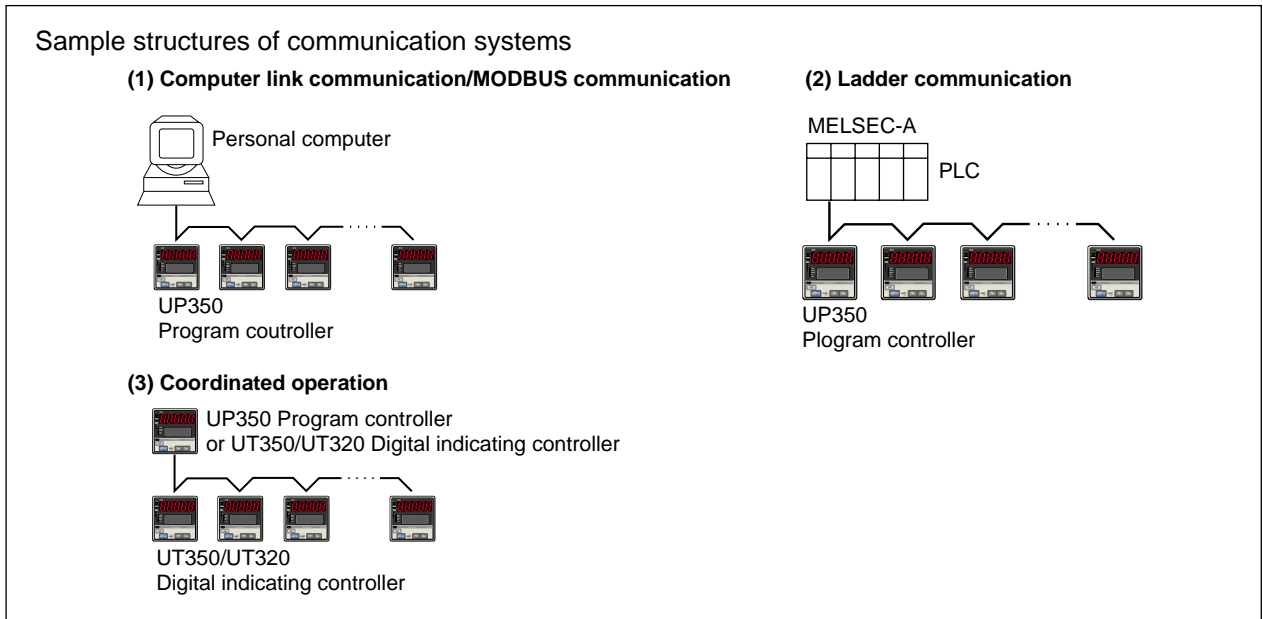

## Hardware Specifications

### Measured Input Signal

- Number of inputs: 1 point
- Input type: Possible to select input type/measurement ranges from the input list with software.
- Input type, measurement ranges, and measurement accuracy: Refer to the table in the next page.
- Burnout detection:
  - Available with TC, RTD, standard signal, 0.4 to 2 V DC and 1 to 5 V DC.
  - Up-scale, down-scale, and off can be set.
  - For standard signal, an input of 0.1V or less is regarded as burnout.
- Input bias current: 0.05  $\mu$ A (for TC and RTD b-terminal)
- Measuring current (RTD): about 0.13mA
- Input resistance:
  - 1 M $\Omega$  or more for TC/mV input
  - About 1 M $\Omega$  for DC voltage input
- Allowable signal source resistance:
  - 250  $\Omega$  or less; effect of permissible signal source resistance 0.1  $\mu$ V/ $\Omega$  or less for TC/mV input
  - 2 k $\Omega$  or less; effect of permissible signal source resistance 0.01%/100  $\Omega$  or less for DC voltage input
- Allowable leadwire resistance:
  - Max. of 150  $\Omega$ /wire (resistance in each of three wires must be equal) for RTD input
  - However, 10  $\Omega$ /wire in the range of -150.0 to 150.0 $^{\circ}$ C.

- Effect of permissible leadwire resistance  $\pm 0.1^{\circ}$ C/10  $\Omega$  or less
- Allowable input voltage:
  - $\pm 10$  V DC for TC/mV/RTD input
  - $\pm 20$  V DC for DC voltage input
- Noise rejection ratio:
  - Normal mode 40 dB (50/60 Hz) or more
  - Common mode 120 dB (50/60 Hz) or more
- Reference-junction compensation error:
  - $\pm 1.0^{\circ}$ C (15 to 35 $^{\circ}$ C),  $\pm 1.5^{\circ}$ C (0 to 15 $^{\circ}$ C, 35 to 50 $^{\circ}$ C)
- Applicable standards: JIS, IEC, or DIN (ITS-90) for TC and RTD

### 15V DC Loop Power Supply

The controller supplies power to a two-wire transmitter. Place a resistor (10 to 250  $\Omega$ , optional) between the controller and the transmitter, convert a current signal to a voltage signal, and read it from the PV input. Either the retransmission output or the loop power supply can be used. Supply voltage is 14.5 to 18.0 V DC. Maximum supply current is about 21 mA (with a protection circuit for a field short-circuit).

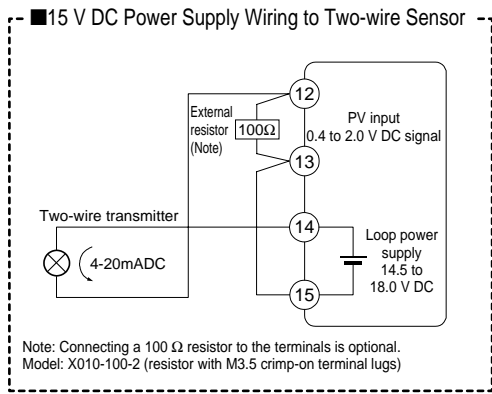

**Retransmission Output**

Either PV, target setpoint, or control output is output. Either the retransmission output or the 15 V DC loop power supply can be used.

- Number of output points: 1 point
- Output signal: 4 to 20 mA DC
- Load resistance: 600 Ω or less
- Output accuracy: ±0.3% of span
- Performance in the standard operating conditions (at 23± 2°C, 55± 10% RH, and 50/60 Hz power frequency)

**Control Outputs**

The control output is of a universal scheme and can be selected from the following types of outputs.

- Current output**
  - Number of output points: 1
  - Output signal: 4 to 20 mA
  - Load resistance: 600 Ω or less
  - Output accuracy: ±0.3% of span
  - Performance in the standard operating conditions (at 23± 2°C, 55± 10% RH, and 50/60 Hz power frequency)
- Voltage pulse output**
  - Number of outputs: 1
  - Output signal: ON voltage 12 V DC (for load resistance of 600Ω or more, short-circuit current approximately 30 mA)
  - OFF voltage 0.1V DC or less
  - Resolution: 10 ms
- Relay contact output**
  - Number of outputs: 1
  - Output signal: Transfer contact, including NC, NO, and Common.
  - Standard rating: 250V AC 3A or 30V DC 3A (Load resistance)
  - Resolution: 10ms

Input type		Input range code	Instrument range (°C)	Instrument range (°F)	Instrument accuracy*1
Unspecified(when shipped from the factory)		OFF	Set the data item PV input type "IN" to the OFF option to leave the PV input type undefined.		
Thermocouple	K	1	-200 to 1370°C	-300 to 2500°F	At or above 0°C ±0.1% ±1 digit of F.S. Below 0°C, ±0.2% ±1 digit of F.S.
		2	-199.9 to 999.9°C	0 to 2300°F	
		3	-199.9 to 500.0°C	-199.9 to 999.9°F	
	J	4	-199.9 to 999.9°C	-300 to 2300°F	
	T	5	-199.9 to 400.0°C	-300 to 750°F	
		6	0.0 to 400.0°C	-199.9 to 750.0°F	
	B	7	0 to 1800°C	32 to 3300°F	At or above 400°C ±0.15% ±1 digit of F.S. Below 400°C ±5% ±1 digit of F.S.
	S	8	0 to 1700°C	32 to 3100°F	±0.15% ±1 digit of F.S.
	R	9	0 to 1700°C	32 to 3100°F	
	N	10	-200 to 1300°C	-300 to 2400°F	±0.1% ±1 digit of F.S. Below 0°C ±0.25% ±1 digit of F.S.
			0.0 to 400.0°C	-199.9 to 750.0°F	
	E	11	-199.9 to 999.9°C	-300 to 1800°F	At or above 0°C ±0.1% ±1 digit of F.S. Below 0°C ±0.2% ±1 digit of F.S.
	L (DIN)	12	-199.9 to 900.0°C	-300 to 1300°F	
	U (DIN)	13	-199.9 to 400.0°C	-300 to 750°F	±0.2% ±1 digit of F.S.
			0.0 to 400.0°C	-199.9 to 750.0°F	
	W (DIN)	15	0 to 2300°C	32 to 4200°F	±0.1% ±1 digit of F.S.
	Platinel 2	16	0 to 1390°C	32 to 2500°F	
	PR20-40	17	0 to 1900°C	32 to 3400°F	At or above 800°C ±0.5% ±1 digit of F.S. Below 800°C, not guaranteed
W97Re3-W75Re25	18	0 to 2000°C	32 to 3600°F	±0.2% ±1 digit of F.S.	
RTD	JPt100	30	-199.9 to 500.0°C	-199.9 to 999.9°F	±0.1% ±1 digit of F.S. (Note1) (Note2)
		31	-150.0 to 150.0°C	-199.9 to 300.0°F	
	Pt100	35	-199.9 to 850.0°C	-300 to 1560°F	±0.1% ±1 digit of F.S. (Note1) (Note2)
		36	-199.9 to 500.0°C	-199.9 to 999.9°F	
		37	-150.0 to 150.0°C	-199.9 to 300.0°F	
Standard signal	0.4 to 2V	40	0.400 to 2.000 V	Scaling is enable in the following 4 range.	±0.1% ±1 digit of F.S.
	1 to 5V	41	1.000 to 5.000 V		
DC voltage	0 to 2V	50	0.000 to 2.000 V		
	0 to 10V	51	0.00 to 10.00 V		
	-10 to 20mV	55	-10.00 to 20.00 mV		
	0 to 100mV	56	0.0 to 100.0 mV		

Note1: The accuracy is ±0.3°C of instrument range ±1 digit for a temperature range from 0 to 100°C.

Note2: The accuracy is ±0.5°C of instrument range ±1 digit for a temperature range from -100 to 200°C.

\*1: Performance in the standard operating conditions (at 23±2°C, 55±10% RH, and 50/60Hz power frequency)

**Contact Inputs**

- Usage: Program pattern selection, program operation hold mode switching, display key lock parameter enabled/disabled switching
- Number of inputs: 2 points
- Input type: non-voltage contact input or transistor open collector input
- Input contact capacity: 12 V DC, 10 mA or more (for non-voltage contact input)
- On/off detection:
- For non-voltage contact input,
    - ON=contact resistance of 1k $\Omega$  or less,
    - OFF=contact resistance of 20k $\Omega$  or more.
  - For transistor open collector input,
    - ON=2V or less,
    - OFF=leak current of 100 $\mu$ A or less.
- Minimum retention time for status detection: about 1 s

**Contact Outputs**

- Usage: Event output
- Number of relay contact outputs: 3 points
- Relay contact rating: 240 V AC 1A, or 30 V DC 1A, make contact

**● Display Specifications**

- Process variable display unit:
- 4-digit 7-segment red LED; each digit 20 mm in height
- Parameter display:
- 4-digit 7-segment red LED; each digit 9.3 mm in height
- Status indicating lamps: LEDs

**● Conformance to Safety and EMC Standards**

- Safety standard:
- Conforms to IEC1010-1: 1990 and EN61010-1: 1992.
  - Certified for CSA1010. The voltage category of each input is CAT II (IEC1010-1)
  - Certified for UL 508 application
- EMC standards:
- Conforms to the following standards.
  - During test, the controller continues to operate with the measurement accuracy within  $\pm 20\%$  of the range.
  - EMI (Emission) EN61326-1: 1997+Am1: 1998
  - EMS (immunity) EN61326-1: 1997+Am1: 1998

**● Construction, Installation, and Wiring**

- Structure: Dust-proof and Drip-proof front panel conforming to IP55.  
For side-by-side close installation, the controller loses its dust-proof and drip-proof protection.
- Body construction: ABS resin and polycarbonate
- Case color: Black
- Weight: Approx. 1 kg or less
- Dimensions: 96W  $\times$  96H  $\times$  100D (from the front panel) (mm)
- Mounting: Direct panel mounting; mounting bracket, one each for upper and lower mounting.
- Panel cutout dimensions: 92<sup>+0.8</sup><sub>0</sub> (W)  $\times$  92<sup>+0.8</sup><sub>0</sub> (H) mm
- Mounting attitude: Up to 30 degrees above the horizontal.  
No downward tilting allowed.
- Wiring: M3.5 screw terminal (signals, power supply/ground)

**● Power Supply / Isolation**

- Power supply: Voltage rating at 100 to 240 V AC ( $\pm 10\%$ ), 50/60 Hz
- Power consumption: MAX. 20VA (MAX. 8.0W)
- Memory back-up: Non-volatile memory (Service life approx. 100,000 times of writings)
- Withstanding voltage:
- Between primary terminal and secondary terminal: 1500V AC for 1 min. (Note)
  - Between primary terminal and ground terminal: 1500V AC for 1 min. (Note)
  - Between ground terminal and secondary terminal: 1500V AC for 1 min.
  - Between two secondary terminals: 500V AC for 1 min
- (Primary terminal: Power supply, relay output  
Secondary terminal:  
Analog input/output signal terminals,  
voltage pulse output terminal, contact  
input terminal)

Note. The withstanding voltage is specified as 2300V AC per minute to provide a margin of safety.

- Isolation resistance:
- Between power supply terminal and ground terminal, 500 V DC 20 M $\Omega$
- Ground: class 3 grounding (grounding resistance of 100 $\Omega$  or less)
- Isolation Specifications:
- Measured input terminal:
- Isolated from other input/output terminals.
  - Not isolated from internal circuit.
- Control output (current or voltage pulse output) and retransmission terminals: Not isolated between control and retransmission output terminal mutually, output terminals, Isolated from other input/output terminals and internal circuit.
- Relay contact control output terminals:
- Isolated from other I/O terminals and internal circuits.
- Contact input terminal:
- Not isolated from contact input terminals mutually and communication terminals.
  - Isolated from other input/output terminals and internal circuit.
- Relay contact event output terminal:
- Isolated from other input/output terminals and internal circuit.
- RS-485 communication terminal:
- Not isolated from contact input terminals.
  - Isolated from other input/output, ground and internal terminals.
- Power supply terminal:
- Isolated from other input/output and ground terminals, and internal circuit.
- Ground terminal:
- Isolated from other input/output and ground terminals, and internal circuit.

**● Environmental Conditions**

## Normal operating conditions:

Ambient temperature: 0° to 50°C (less than 40°C when mounted side by side)

Ambient temperature change limit: 10°C/h or less

Ambient humidity: 20 to 90% RH (non-condensing)

Magnetic field: 400 A/m or less

Continuous vibration (5 to 14 Hz):

Amplitude of 1.2 mm or less

Continuous vibration (14 to 150 Hz):

4.9 m/s<sup>2</sup> or less

Short-period vibration: 14.7 m/s<sup>2</sup>, 15s. or less

Shock: 147 m/s<sup>2</sup> or less, 11 ms.

Installation altitude:

2,000 m above sea level maximum

Warm-up time: 30 minutes or more

## Transit/storage conditions:

Temperature: -25° to 70°C

Temperature change limit: 20°C/h or less

Humidity: 5 to 95% RH (non-condensing)

## Effects on operating conditions

## Effect of ambient temperature:

For voltage/TC input, within  $\pm 1\mu\text{V}/^\circ\text{C}$  and  $\pm 0.01\%$  of F.S./°C, whichever is greater.

For RTD input, within  $\pm 0.05\text{ }^\circ\text{C}/^\circ\text{C}$  (ambient temperature)

For analog output,  $\pm 0.05\%$  of F.S./°C or less

## Effect of power supply fluctuation (within rated voltage range):

For analog input, within  $\pm 1\mu\text{V}/10\text{V}$  and  $\pm 0.01\%$  of F.S./10V, whichever is greater.

For analog output, within  $\pm 0.05\%$  of F.S./10V

## ■ Function Block Diagram for Single-loop Control

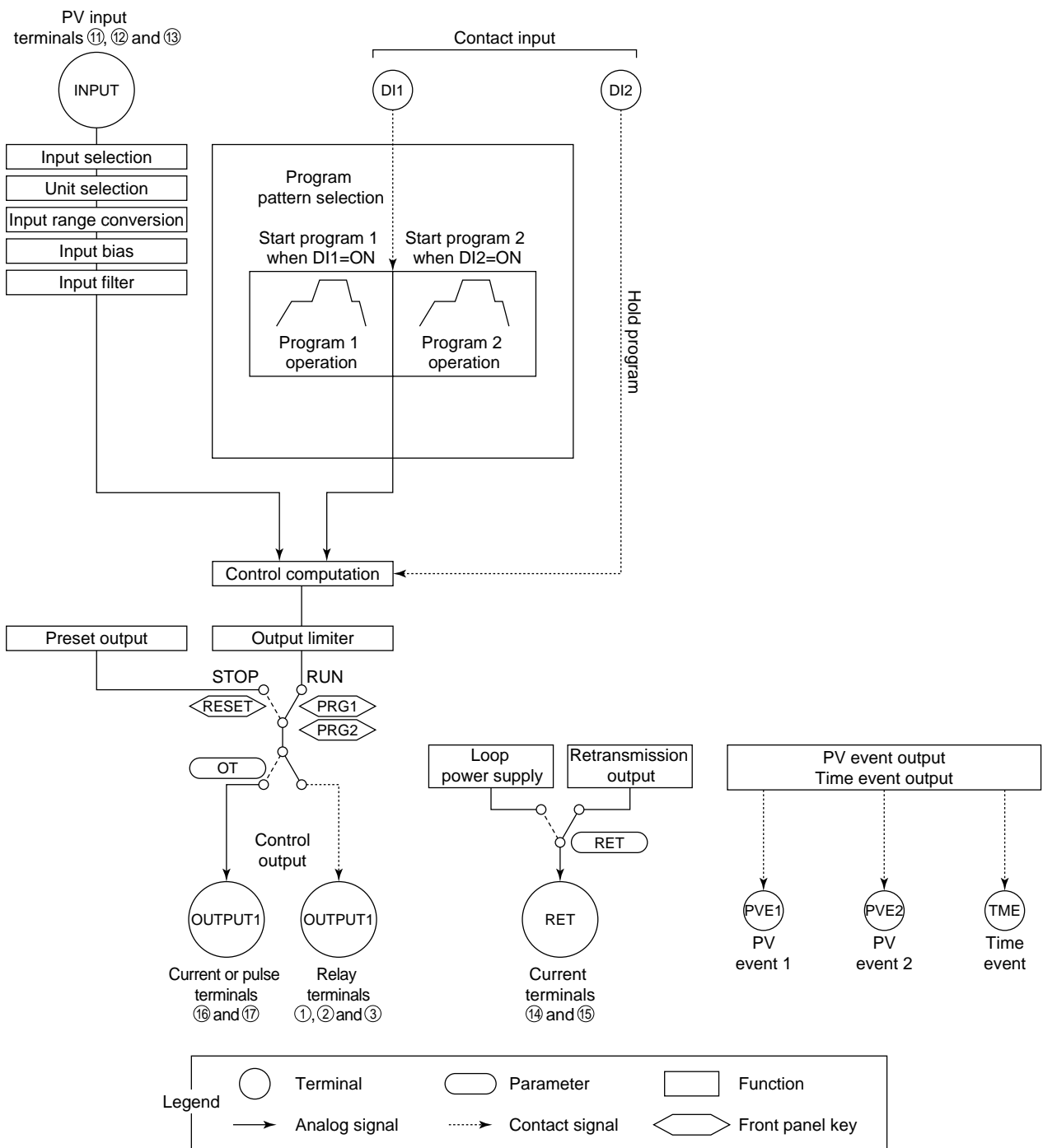

\* DIS is a setup parameter.  
Changing DIS setpoint allows you to change the function of external contact input.

Correspondence between parameter DIS and external contact input functions			
When DIS=OFF (Factory-set default)	When DIS=1	When DIS=2	When DIS=3
No function	Start program 1 when DI1 = ON Reset program 1 when DI1 = OFF	Hide setup parameter lock when DI1 = ON Show setup parameter lock when DI1 = OFF	Start program 1 when DI1 = ON Reset program 1 when DI1 = OFF
No function	Start program 2 when DI2 = ON Reset program 2 when DI2 = OFF	No function	Hold program when DI2 = ON Cancel hold when DI2 = OFF

# UP350 Standard Type, Terminal Arrangements.

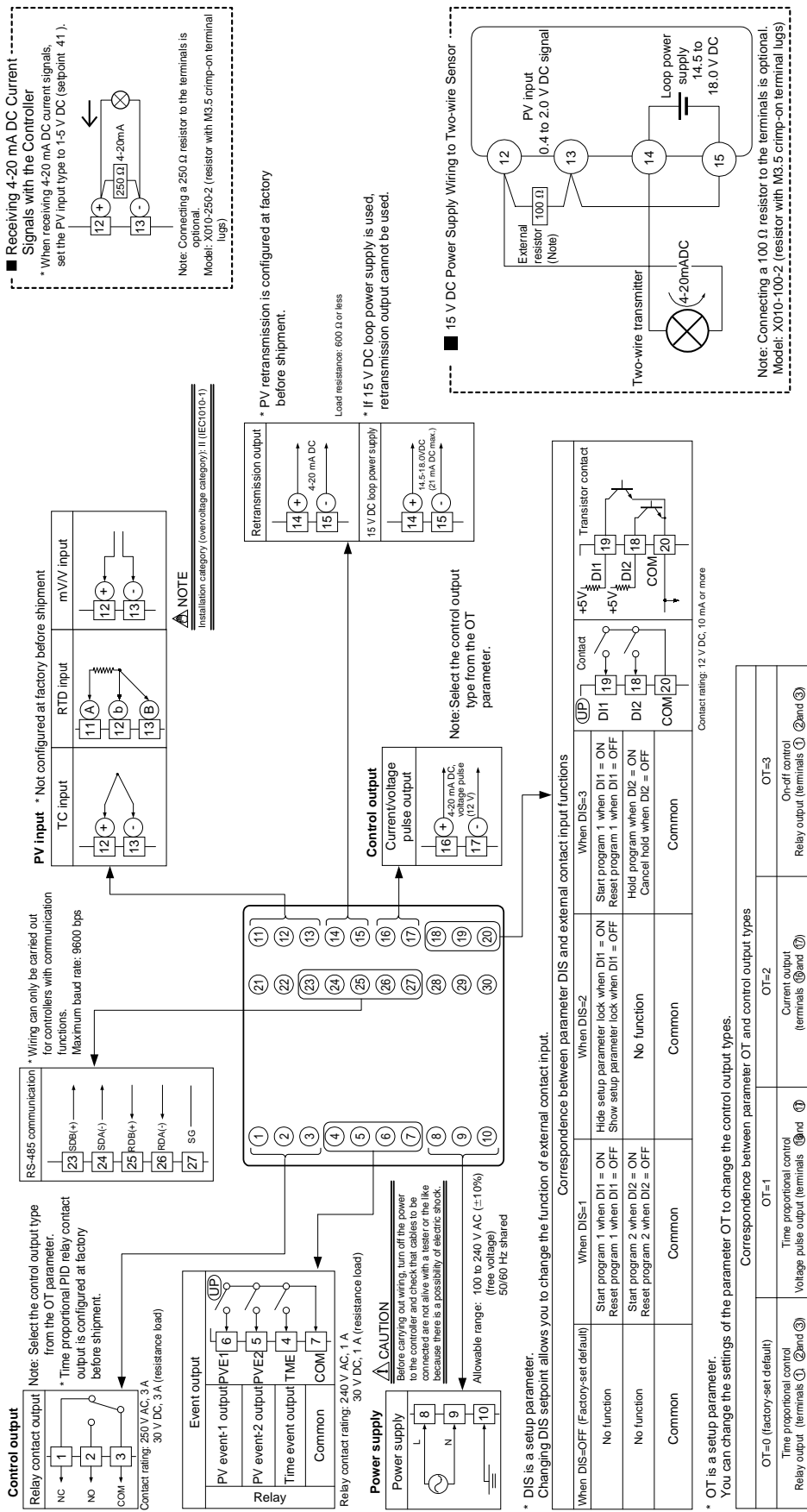

**External Dimensions and Panel Cutout Dimension**

UP350

Unit: mm

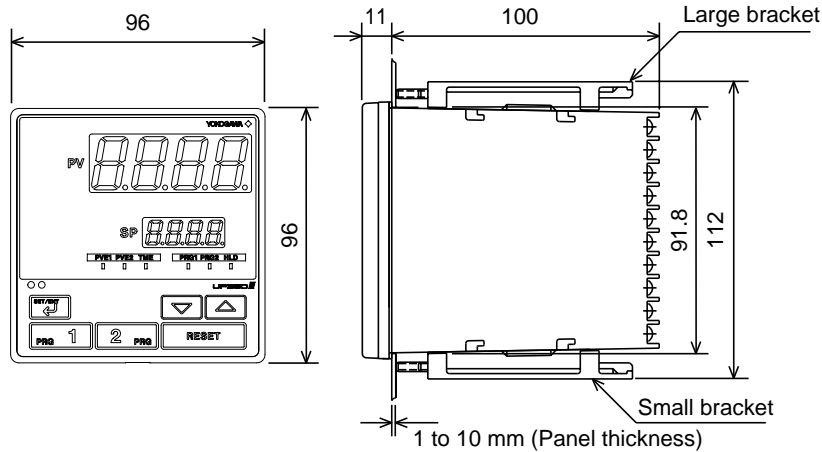

General installation

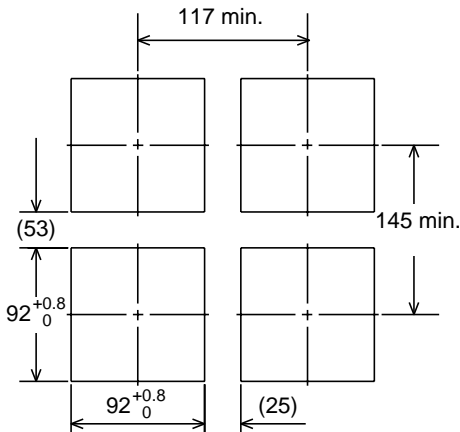

Side-by-side close installation

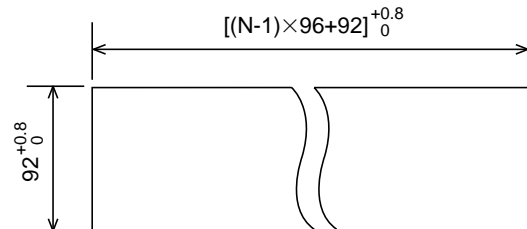

"N" stands for the number of controllers to be installed.  
However, the measured value applies if  $N \geq 5$ .

**Model and Suffix Codes**

Model	Suffix Code	Description
UP350		Program controller (provided with retransmission output and 15 V DC loop power supply as standard)
Type	-0	Standard type
Optional functions	0	None
	1	With communication

Standard accessories: Brackets (mounting hardware), unit label, User's Manuals, and User's Manual (reference) (CD-ROM version).

**Items to be specified when ordering**

Model and suffix codes, necessary/unnecessary of User's Manual or QIC.